



Features

- Three floating high-side drivers in bootstrap operation to 600V
- 420mA source / 750mA sink output current capability
- Logic input 3.3V capability
- Internal deadtime of 315ns to protect MOSFETs
- Matched prop delay time maximum of 50ns
- Outputs in phase with inputs
- Schmitt triggered logic inputs
- Cross conduction prevention logic
- Undervoltage lockout for all channels
- Extended temperature range: -40°C to +125°C
- Space saving SOIC-20 package

Applications

- 3-Phase Motor Inverter Driver
- White Goods - Air Conditioner, Washing Machine, Refrigerator
- Industrial Motor Inverter - Power Tools, Robotics
- General Purpose 3-Phase Inverter

SOIC-20

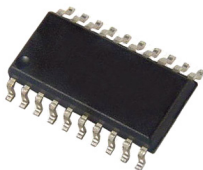

Description

The TF2388M is a three-phase gate driver IC designed for high voltage three-phase applications, driving N-channel MOSFETs and IGBTs in a half-bridge configuration. TF Semiconductor’s high voltage process enables the TF2388M high sides to switch to 600V in a bootstrap operation.

The TF2388M logic inputs are compatible with standard TTL and CMOS levels (down to 3.3V) to interface easily with controlling devices and are enabled low to better function in high noise environments. The driver outputs feature high pulse current buffers designed for minimum driver cross conduction.

The TF2388M offers numerous protection functions. A shoot-through protection logic prevents both outputs being high with both inputs high (fault state), an undervoltage lockout for V_{CC} shuts down all drivers through an internal fault control, and a UVLO for V_{BS} shuts down the respective high side output. The TF2388M is offered in SOIC 20 package and operates over an extended -40 °C to +125 °C temperature range.

Ordering Information

Year Year Week Week

PART NUMBER	PACKAGE	PACK / Qty	MARK
TF2388M-TGU	SOIC-20	Tube / 35	YYWW TF2388M
TF2388M-TGH	SOIC-20	T&R / 1500	Lot ID

Pin Diagrams

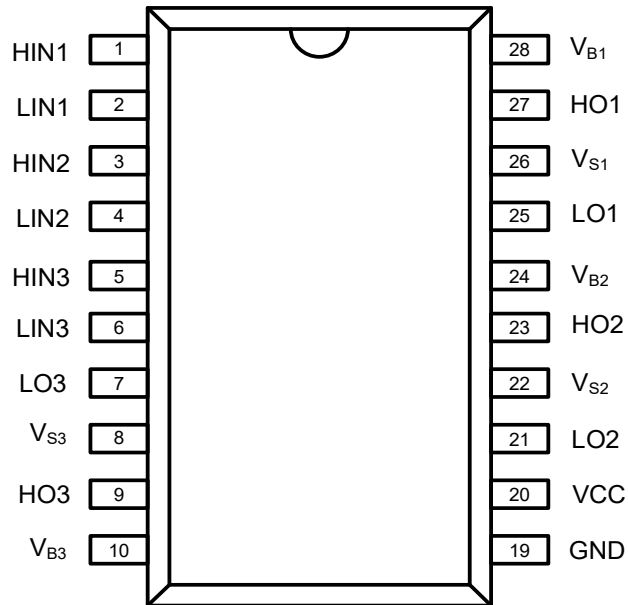

Top View: SOIC-20

Pin Descriptions

PIN NAME	PIN NUMBER	PIN DESCRIPTION
HIN1, HIN2, HIN3	1, 3, 5	Logic input for high-side gate driver output, in phase with HO.
LIN1, LIN2, LIN3	2, 4, 6	Logic input for low-side gate driver output, in phase with LO.
LO3, LO2, LO1	7, 13, 17	Low-side gate driver output
V_{S3}, V_{S2}, V_{S1}	8, 14, 18	High-side floating supply return
HO3, HO2, HO1	9, 15, 19	High-side gate driver output
V_{B3}, V_{B2}, V_{B1}	10, 16, 20	High-side floating supply
GND	11	Low-side driver and logic return
VCC	12	Low-side and logic fixed supply

Revision History

Rev.	Change	Owner	Date
1.0	First release datasheet	D. Walton	12/8/2022

for additional information contact: info@tfsemiconductors.com

Important Notice

TF Semiconductor Solutions (TFSS) PRODUCTS ARE NEITHER DESIGNED NOR INTENDED FOR USE IN MILITARY AND/OR AEROSPACE, AUTOMOTIVE OR MEDICAL DEVICES OR SYSTEMS UNLESS THE SPECIFIC TFSS PRODUCTS ARE SPECIFICALLY DESIGNATED BY TFSS FOR SUCH USE. BUYERS ACKNOWLEDGE AND AGREE THAT ANY SUCH USE OF TFSS PRODUCTS WHICH TFSS HAS NOT DESIGNATED FOR USE IN MILITARY AND/OR AEROSPACE, AUTOMOTIVE OR MEDICAL DEVICES OR SYSTEMS IS SOLELY AT THE BUYER'S RISK.

TFSS assumes no liability for application assistance or customer product design. Customers are responsible for their products and applications using TFSS products.

Resale of TFSS products or services with statements different from or beyond the parameters stated by TFSS for that product or service voids all express and any implied warranties for the associated TFSS product or service. TFSS is not responsible or liable for any such statements.

©2022 TFSS. All Rights Reserved. Information and data in this document are owned by TFSS wholly and may not be edited, reproduced, or redistributed in any way without the express written consent from TFSS.

For additional information please contact support@tfsemi.com or visit www.tfsemi.com.